

Separation Techniques

Filtration

Size of particles

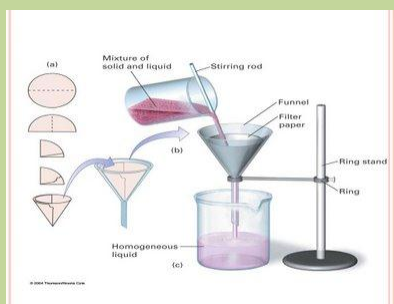
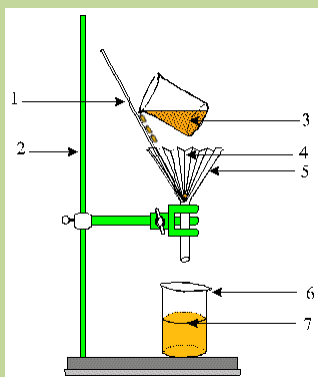

Chromatography

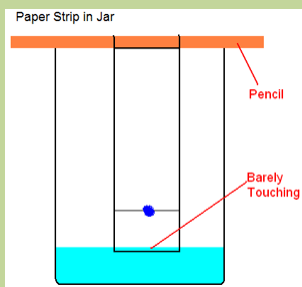

Magnetism

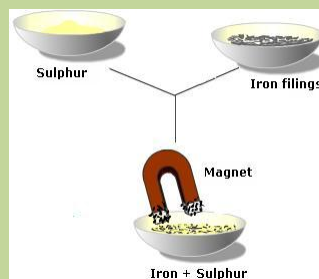

Distillation

Boiling point

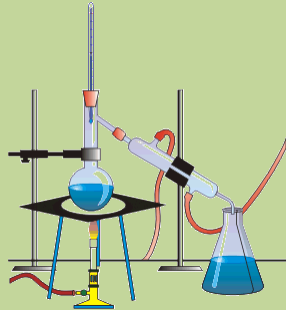

Evaporation results in Crystallization

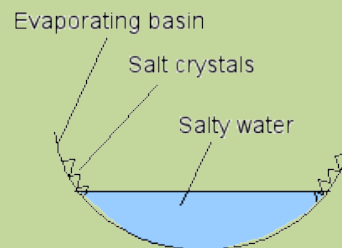
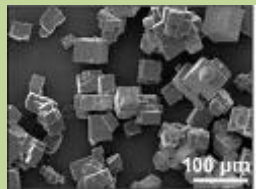

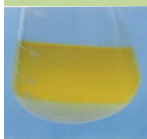

Density: Decanting/ Centrifuging

More dense liquid/solid on bottom
less dense on top

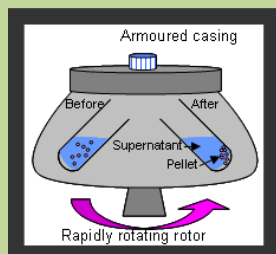
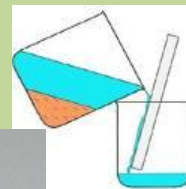

Only Separation Technique that is a
chemical change is.....



Electrolysis

Only one that is chemical separation

